



LDH1 system

PRODUCT CATALOGUE

ATLAS COPCO INTERFACE

Germany

Johannes Lübbering GmbH
Industriestraße 4
33442 Herzebrock-Clarholz

Telephone: +49 (52 45) 83 09-0
Fax: +49 (52 45) 83 09-250
info@luebbering.de
www.luebbering.de

United Kingdom

Luebbering (UK) Ltd.
418 Oakshott Place
Walton Summit Industrial Estate
Bamber Bridge
Preston
Lancashire
PR5 8AT

Telephone: +44 (1772) 312288
Fax: +44 (19 25) 751-752
info@luebbering.co.uk
www.luebbering.co.uk

China

Lübbering Tools Trading (Shanghai) Co., Ltd.
www.luebbering.com

USA

Luebbering Corp.
www.luebbering.com

TABLE OF CONTENTS

1.	GENERAL INFORMATION	4
1.1	Overview	5
1.2	Collet chucks	6
1.3	Drilling tools	6
2.	ATLAS COPCO INTERFACE	7
2.1	Tools	7
2.2	L.DH1 system 03-XX-XX – straight	8
2.3	L.DH1 system 04-XX-XX – straight	9
2.4	L.DH1 system 06-XX-XX – straight	10
2.5	L.DH1 system 08-XX-XX – straight	11
2.6	L.DH1 system 06-XX-XX – right-angled	12
2.7	L.DH1 system 06-XX-XX – left-angled	13

1. GENERAL INFORMATION

L.DH1 system drilling systems are available in wide range of designs to match your specific application.

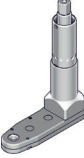
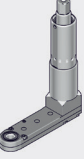
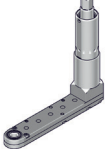
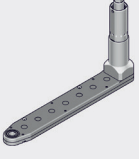
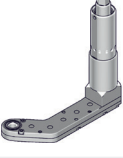
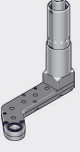
L.DH1 SYSTEM		ALIGNMENT
03-XX-XX		
04-XX-XX		straight
06-XX-XX		
08-XX-XX		
06-XX-XX		
06-XX-XX		left-angled

These can be used in combination with commercially available tools from Atlas Copco thanks to the various different adapter interfaces for L.DH1.

Depending on requirements, we offer thread sockets and collet chuck sockets in various sizes.

Drilling tools with a diameter of up to 8 mm can be used. The L.DH1 drilling offset head is designed for the most demanding requirements and for the speeds achieved by commercially available tools.

1.1 OVERVIEW

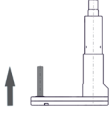
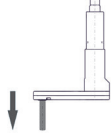
SOCKET FOR DRILLING TOOL / COLLET CHUCK		DRILLING SYSTEM		TOOL	FURTHER INFORMATION
SIZE	INSTALLATION DIRECTION	L.DH1 SYSTEM	ALIGNMENT	INTERFACE	
<p>THREAD 1/4-28 UNF-2B FOR DRILLING TOOLS</p> <p>THREAD 9/32-40 UNS FOR COLLET CHUCKS</p>	<p>top</p> 	03-XX-XX	straight	Atlas Copco	Further information on page 8
	<p>bottom</p> 	06-XX-XX		Atlas Copco	Further information on page 9
		06-XX-XX		Atlas Copco	Further information on page 10
		08-XX-XX		Atlas Copco	Further information on page 11
		06-XX-XX	right-angled	Atlas Copco	Further information on page 12
	06-XX-XX	left-angled	Atlas Copco	Further information on page 13	

1.2 COLLET CHUCKS

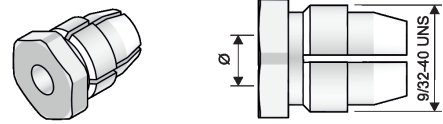

SOCKET Ø [mm]	ITEM NO.	SOCKET Ø [mm]	ITEM NO.	SOCKET Ø [mm]	ITEM NO.	SOCKET Ø [mm]	ITEM NO.	SOCKET Ø [mm]	ITEM NO.
1,0	37200001	1,9	37200010	2,8	37200019	3,7	37200028	4,6	37200037
1,1	37200002	2,0	37200011	2,9	37200020	3,8	37200029	4,7	37200038
1,2	37200003	2,1	37200012	3,0	37200021	3,9	37200030	4,8 (3/16")	37200039
1,3	37200004	2,2	37200013	3,1	37200022	4,0 (5/32")	37200031	4,9	37200040
1,4	37200005	2,3	37200014	3,2	37200023	4,1	37200032	5,0	37200041
1,5	37200006	2,4 (3/32")	37200015	3,3	37200024	4,2	37200033		
1,6 (1/16")	37200007	2,5	37200016	3,4	37200025	4,3	37200034		
1,7	37200008	2,6	37200017	3,5	37200026	4,4	37200035		
1,8	37200009	2,7	37200018	3,6	37200027	4,5	37200036		

1.3 DRILLING TOOLS

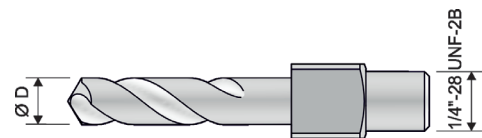

Ø D [mm]	ITEM NO.	Ø D [mm]	ITEM NO.	Ø D [mm]	ITEM NO.	Ø D [mm]	ITEM NO.	Ø D [mm]	ITEM NO.
1,78	37300050	2,49	37300040	3,27	37300030	4,09	37300020	4,92	37300010
1,85	37300049	2,53	37300039	3,45	37300029	4,22	37300019	4,98	37300009
1,93	37300048	2,58	37300038	3,57	37300028	4,30	37300018	5,06	37300008
1,99	37300047	2,64	37300037	3,66	37300027	4,39	37300017	5,11	37300007
2,06	37300046	2,71	37300036	3,73	37300026	4,50	37300016	5,18	37300006
2,08	37300045	2,79	37300035	3,80	37300025	4,57	37300015	5,22	37300005
2,18	37300044	2,82	37300034	3,86	37300024	4,62	37300014	5,31	37300004
2,26	37300043	2,87	37300033	3,91	37300023	4,70	37300013	5,41	37300003
2,37	37300042	2,95	37300032	3,99	37300022	4,80	37300012	5,61	37300002
2,44	37300041	3,05	37300031	4,04	37300021	4,85	37300011	5,79	37300001

2. ATLAS COPCO INTERFACE

2.1 TOOLS

TYPE	MODEL	MANUFACTURER NO.	ROTATIONAL SPEED [rpm]	OUTPUT [W]
PISTOL	LBP16M-005	8421012405	500	340
	LBP16M-010	8421012410	1000	340
	LBP16M-018	8421012418	1800	340
	LBP16M-033	8421012433	3300	340
	LBP16M-045	8421012445	4500	340
	LBP16M-060	8421012460	6000	340
STRAIGHT	LBD16M-005	8421012205	200 – 500	300
	LBD16M-010	8421012210	500 – 1000	300
	LBD16M-018	8421012218	800 – 1800	300
	LBD16M-032	8421012232	1500 – 3200	300
	LBD16M-045	8421012245	3200 – 4500	300
	LBD16M-055	8421012255	4500 – 5500	300



2.2 L.DH1 SYSTEM 03-XX-XX – STRAIGHT

Interface to drilling tool / collet chuck „X“

FOR DRILLING TOOL	FOR COLLET CHUCK	INSTALLATION DIRECTION
Thread 1/4-28 UNF-2B	Thread 9/32-40 UNS	top

Interface with the tool „Y“

MANUFACTURER	TYPE
Atlas Copco	Chapter 2.1 'Tools' on page 7

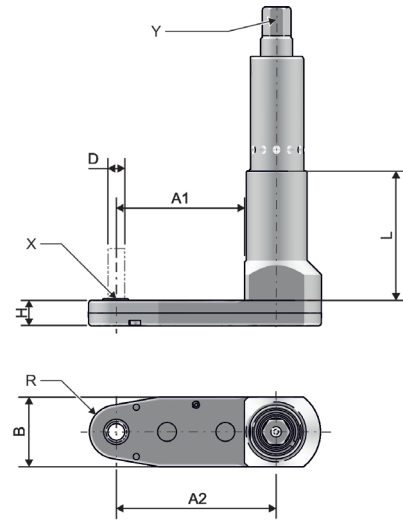

ITEM NO.	TYPE	MAX. Ø D [mm]	X	H [mm]	A1 [mm]	A2 [mm]	B [mm]	R [mm]	L [mm]	WEIGHT [kg]
99230805	03-08-48,5	5,0	1/4-28 UNF-2B	8,0	40,4	50,4	24,0	8,5	40,5	0,221
99230806	03-08-128	5,0	1/4-28 UNF-2B	8,0	40,4	50,4	24,0	8,5	120,0	0,346
99231002	03-10-50,5	6,35	1/4-28 UNF-2B	10,0	40,4	50,4	24,0	8,5	40,5	0,239
99231007	03-10-130	6,35	1/4-28 UNF-2B	10,0	40,4	50,4	24,0	8,5	120,0	0,364
99231305	03-12,5-53	8,0	1/4-28 UNF-2B	12,5	40,4	50,4	24,0	8,5	40,5	0,266
99231306	03-12,5-132,5	8,0	1/4-28 UNF-2B	12,5	40,4	50,4	24,0	8,5	120,0	0,391
99230807	03-08-48,5	5,0	9/32-40 UNS	8,0	40,4	50,4	24,0	8,5	40,5	0,221
99230808	03-08-128	5,0	9/32-40 UNS	8,0	40,4	50,4	24,0	8,5	120,0	0,346
99231008	03-10-50,5	6,35	9/32-40 UNS	10,0	40,4	50,4	24,0	8,5	40,5	0,239
99231009	03-10-130	6,35	9/32-40 UNS	10,0	40,4	50,4	24,0	8,5	120,0	0,364
99231302	03-12,5-53	8,0	9/32-40 UNS	12,5	40,4	50,4	24,0	8,5	40,5	0,265
99231307	03-12,5-132,5	8,0	9/32-40 UNS	12,5	40,4	50,4	24,0	8,5	120,0	0,390



2.3 L.DH1 SYSTEM 04-XX-XX – STRAIGHT

Interface to drilling tool / collet chuck „X“

FOR DRILLING TOOL	FOR COLLET CHUCK	INSTALLATION DIRECTION
Thread 1/4-28 UNF-2B	Thread 9/32-40 UNS	bottom

Interface with the tool „Y“

MANUFACTURER	TYPE
Atlas Copco	Chapter 2.1 'Tools' on page 7

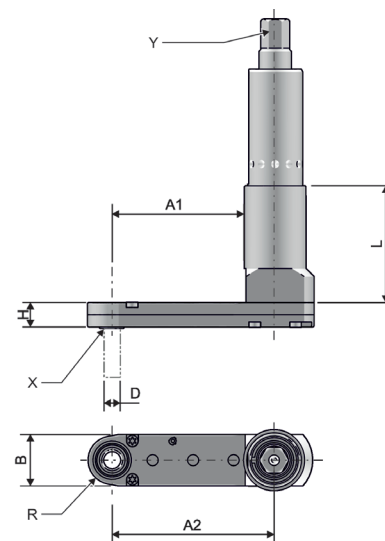

ITEM NO.	TYPE	MAX. Ø D [mm]	X	H [mm]	A1 [mm]	A2 [mm]	B [mm]	R [mm]	L [mm]	WEIGHT [kg]
99240807	04-7,5-43,5	5,0	1/4-28 UNF-2B	7,5	40,9	50,4	16,0	7,5	36,0	0,173
99240808	04-08-48,5	5,0	1/4-28 UNF-2B	8,0	58,8	68,8	24,0	8,5	40,5	0,247
99240809	04-08-128	5,0	1/4-28 UNF-2B	8,0	58,8	68,8	24,0	8,5	120,0	0,372
99241005	04-10-50,5	6,35	1/4-28 UNF-2B	10,0	58,8	68,8	24,0	8,5	40,5	0,271
99241006	04-10-130	6,35	1/4-28 UNF-2B	10,0	58,8	68,8	24,0	8,5	120,0	0,396
99241306	04-12,5-53	8,0	1/4-28 UNF-2B	12,5	58,8	68,8	24,0	8,5	40,5	0,303
99241307	04-12,5-132,5	8,0	1/4-28 UNF-2B	12,5	58,8	68,8	24,0	8,5	120,0	0,428
99240810	04-7,5-43,5	5,0	9/32-40 UNS	7,5	40,9	50,4	16,0	7,5	36,0	0,173
99240811	04-08-48,5	5,0	9/32-40 UNS	8,0	58,8	68,8	24,0	8,5	40,5	0,247
99240812	04-08-128	5,0	9/32-40 UNS	8,0	58,8	68,8	24,0	8,5	120,0	0,372
99241007	04-10-50,5	6,35	9/32-40 UNS	10,0	58,8	68,8	24,0	8,5	40,5	0,270
99241008	04-10-130	6,35	9/32-40 UNS	10,0	58,8	68,8	24,0	8,5	120,0	0,395
99241308	04-12,5-53	8,0	9/32-40 UNS	12,5	58,8	68,8	24,0	8,5	40,5	0,303
99241309	04-12,5-132,5	8,0	9/32-40 UNS	12,5	58,8	68,8	24,0	8,5	120,0	0,428



2.4 L.DH1 SYSTEM 06-XX-XX – STRAIGHT

Interface to drilling tool / collet chuck „X“

FOR DRILLING TOOL	FOR COLLET CHUCK	INSTALLATION DIRECTION
Thread 1/4-28 UNF-2B	Thread 9/32-40 UNS	bottom

Interface with the tool „Y“

MANUFACTURER	TYPE
Atlas Copco	Chapter 2.1 'Tools' on page 7

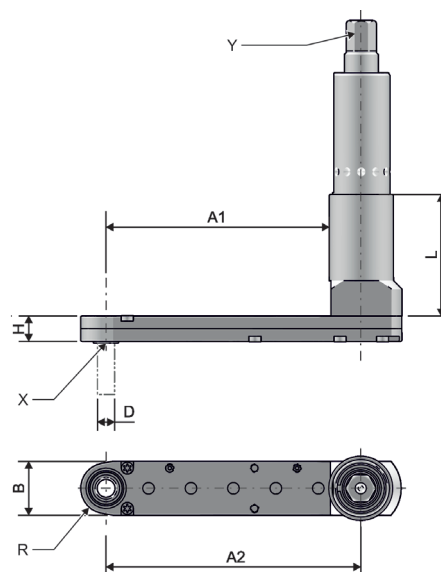

ITEM NO.	TYPE	MAX. Ø D [mm]	X	H [mm]	A1 [mm]	A2 [mm]	B [mm]	R [mm]	L [mm]	WEIGHT [kg]
99260819	06-7,5-43,5	5,0	1/4-28 UNF-2B	7,5	66,1	75,6	16,0	7,5	36,0	0,195
99260820	06-08-48,5	5,0	1/4-28 UNF-2B	8,0	95,6	105,6	24,0	8,5	40,5	0,299
99260821	06-08-128	5,0	1/4-28 UNF-2B	8,0	95,6	105,6	24,0	8,5	120,0	0,424
99261014	06-10-50,5	6,35	1/4-28 UNF-2B	10,0	95,6	105,6	24,0	8,5	40,5	0,333
99261015	06-10-130	6,35	1/4-28 UNF-2B	10,0	95,6	105,6	24,0	8,5	120,0	0,458
99261314	06-12,5-53	8,0	1/4-28 UNF-2B	12,5	95,6	105,6	24,0	8,5	40,5	0,379
99261315	06-12,5-132,5	8,0	1/4-28 UNF-2B	12,5	95,6	105,6	24,0	8,5	120,0	0,504
99260828	06-7,5-43,5	5,0	9/32-40 UNS	7,5	66,1	75,6	16,0	7,5	36,0	0,195
99260829	06-08-48,5	5,0	9/32-40 UNS	8,0	95,6	105,6	24,0	8,5	40,5	0,298
99260830	06-08-128	5,0	9/32-40 UNS	8,0	95,6	105,6	24,0	8,5	120,0	0,423
99261020	06-10-50,5	6,35	9/32-40 UNS	10,0	95,6	105,6	24,0	8,5	40,5	0,333
99261021	06-10-130	6,35	9/32-40 UNS	10,0	95,6	105,6	24,0	8,5	120,0	0,458
99261320	06-12,5-53	8,0	9/32-40 UNS	12,5	95,6	105,6	24,0	8,5	40,5	0,379
99261321	06-12,5-132,5	8,0	9/32-40 UNS	12,5	95,6	105,6	24,0	8,5	120,0	0,504



2.5 L.DH1 SYSTEM 08-XX-XX – STRAIGHT

Interface to drilling tool / collet chuck „X“

FOR DRILLING TOOL	FOR COLLET CHUCK	INSTALLATION DIRECTION
Thread 1/4-28 UNF-2B	Thread 9/32-40 UNS	bottom

Interface with the tool „Y“

MANUFACTURER	TYPE
Atlas Copco	Chapter 2.1 'Tools' on page 7

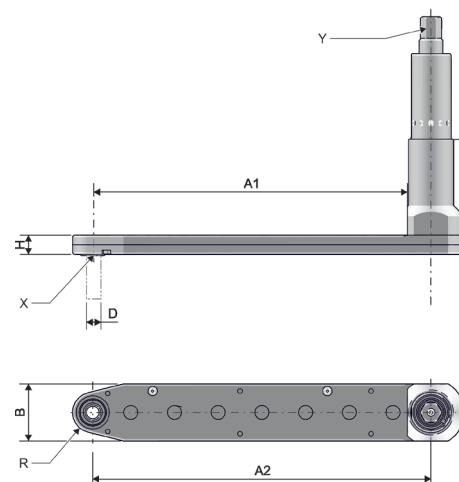

ITEM NO.	TYPE	MAX. Ø D [mm]	X	H [mm]	A1 [mm]	A2 [mm]	B [mm]	R [mm]	L [mm]	WEIGHT [kg]
99280806	08-7,5-43,5	5,0	1/4-28 UNF-2B	7,5	91,3	100,8	16,0	7,5	36,0	0,218
99280807	08-08-48,5	5,0	1/4-28 UNF-2B	8,0	132,4	142,4	24,0	8,5	40,5	0,351
99280808	08-08-128	5,0	1/4-28 UNF-2B	8,0	132,4	142,4	24,0	8,5	120,0	0,476
99281005	08-10-50,5	6,35	1/4-28 UNF-2B	10,0	132,4	142,4	24,0	8,5	40,5	0,396
99281006	08-10-130	6,35	1/4-28 UNF-2B	10,0	132,4	142,4	24,0	8,5	120,0	0,521
99281305	08-12,5-53	8,0	1/4-28 UNF-2B	12,5	132,4	142,4	24,0	8,5	40,5	0,456
99281306	08-12,5-132,5	8,0	1/4-28 UNF-2B	12,5	132,4	142,4	24,0	8,5	120,0	0,581
99280809	08-7,5-43,5	5,0	9/32-40 UNS	7,5	91,3	100,8	16,0	7,5	36,0	0,217
99280810	08-08-48,5	5,0	9/32-40 UNS	8,0	132,4	142,4	24,0	8,5	40,5	0,351
99280811	08-08-128	5,0	9/32-40 UNS	8,0	132,4	142,4	24,0	8,5	120,0	0,476
99281002	08-10-50,5	6,35	9/32-40 UNS	10,0	132,4	142,4	24,0	8,5	40,5	0,396
99281007	08-10-130	6,35	9/32-40 UNS	10,0	132,4	142,4	24,0	8,5	120,0	0,521
99281307	08-12,5-53	8,0	9/32-40 UNS	12,5	132,4	142,4	24,0	8,5	40,5	0,456
99281308	08-12,5-132,5	8,0	9/32-40 UNS	12,5	132,4	142,4	24,0	8,5	120,0	0,581

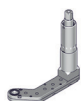

2.6 L.DH1 SYSTEM 06-XX-XX – RIGHT-ANGLED

Interface to drilling tool / collet chuck „X“

FOR DRILLING TOOL	FOR COLLET CHUCK	INSTALLATION DIRECTION
Thread 1/4-28 UNF-2B	Thread 9/32-40 UNS	bottom

Interface with the tool „Y“

MANUFACTURER	TYPE
Atlas Copco	Chapter 2.1 'Tools' on page 7

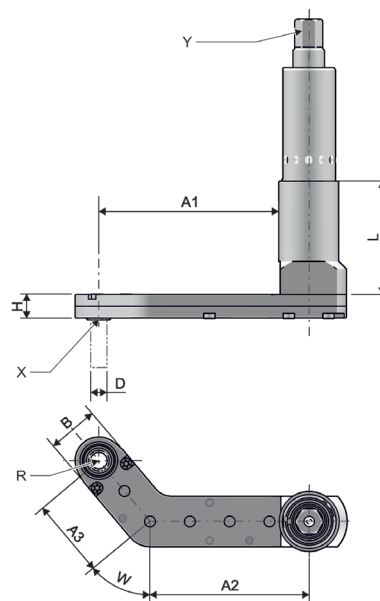

ITEM NO.	TYPE	MAX. Ø D [mm]	X	H [mm]	A1 [mm]	A2 [mm]	A3 [mm]	B [mm]	R [mm]	L [mm]	W [°]	WEIGHT [kg]
99260822	06-7,5-43,5	5,0	1/4-28 UNF-2B	7,5	57,1	50,4	25,2	16,0	7,5	36,0	50,0	0,195
99260823	06-08-48,5	5,0	1/4-28 UNF-2B	8,0	85,5	71,2	34,4	24,0	8,5	40,5	45,0	0,299
99260824	06-08-128	5,0	1/4-28 UNF-2B	8,0	85,5	71,2	34,4	24,0	8,5	120,0	45,0	0,424
99261016	06-10-50,5	6,35	1/4-28 UNF-2B	10,0	85,5	71,2	34,4	24,0	8,5	40,5	45,0	0,333
99261017	06-10-130	6,35	1/4-28 UNF-2B	10,0	85,5	71,2	34,4	24,0	8,5	120,0	45,0	0,458
99261316	06-12,5-53	8,0	1/4-28 UNF-2B	12,5	85,5	71,2	34,4	24,0	8,5	40,5	45,0	0,379
99261317	06-12,5-132,5	8,0	1/4-28 UNF-2B	12,5	85,5	71,2	34,4	24,0	8,5	120,0	45,0	0,504
99260831	06-7,5-43,5	5,0	9/32-40 UNS	7,5	57,1	50,4	25,2	16,0	7,5	36,0	50,0	0,195
99260832	06-08-48,5	5,0	9/32-40 UNS	8,0	85,5	71,2	34,4	24,0	8,5	40,5	45,0	0,298
99260833	06-08-128	5,0	9/32-40 UNS	8,0	85,5	71,2	34,4	24,0	8,5	120,0	45,0	0,423
99261022	06-10-50,5	6,35	9/32-40 UNS	10,0	85,5	71,2	34,4	24,0	8,5	40,5	45,0	0,333
99261023	06-10-130	6,35	9/32-40 UNS	10,0	85,5	71,2	34,4	24,0	8,5	120,0	45,0	0,458
99261325	06-12,5-53	8,0	9/32-40 UNS	12,5	85,5	71,2	34,4	24,0	8,5	40,5	45,0	0,379
99261322	06-12,5-132,5	8,0	9/32-40 UNS	12,5	85,5	71,2	34,4	24,0	8,5	120,0	45,0	0,504



2.7 L.DH1 SYSTEM 06-XX-XX – LEFT-ANGLED

Interface to drilling tool / collet chuck „X“

FOR DRILLING TOOL	FOR COLLET CHUCK	INSTALLATION DIRECTION
Thread 1/4-28 UNF-2B	Thread 9/32-40 UNS	bottom

Interface with the tool „Y“

MANUFACTURER	TYPE
Atlas Copco	Chapter 2.1 'Tools' on page 7

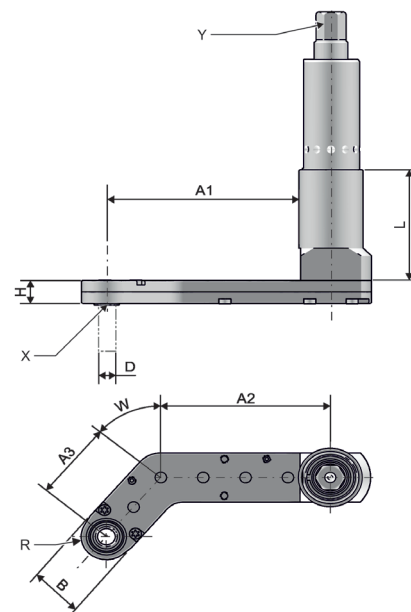

ITEM NO.	TYPE	MAX. Ø D [mm]	X	H [mm]	A1 [mm]	A2 [mm]	A3 [mm]	B [mm]	R [mm]	L [mm]	W [°]	WEIGHT [kg]
99260825	06-7,5-43,5	5,0	1/4-28 UNF-2B	7,5	57,1	50,4	25,2	16,0	7,5	36,0	50,0	0,195
99260826	06-08-48,5	5,0	1/4-28 UNF-2B	8,0	85,5	71,2	34,4	24,0	8,5	40,5	45,0	0,299
99260827	06-08-128	5,0	1/4-28 UNF-2B	8,0	85,5	71,2	34,4	24,0	8,5	120,0	45,0	0,424
99261018	06-10-50,5	6,35	1/4-28 UNF-2B	10,0	85,5	71,2	34,4	24,0	8,5	40,5	45,0	0,333
99261019	06-10-130	6,35	1/4-28 UNF-2B	10,0	85,5	71,2	34,4	24,0	8,5	120,0	45,0	0,458
99261318	06-12,5-53	8,0	1/4-28 UNF-2B	12,5	85,5	71,2	34,4	24,0	8,5	40,5	45,0	0,379
99261319	06-12,5-132,5	8,0	1/4-28 UNF-2B	12,5	85,5	71,2	34,4	24,0	8,5	120,0	45,0	0,504
99260834	06-7,5-43,5	5,0	9/32-40 UNS	7,5	57,1	50,4	25,2	16,0	7,5	36,0	50,0	0,195
99260835	06-08-48,5	5,0	9/32-40 UNS	8,0	85,5	71,2	34,4	24,0	8,5	40,5	45,0	0,298
99260836	06-08-128	5,0	9/32-40 UNS	8,0	85,5	71,2	34,4	24,0	8,5	120,0	45,0	0,423
99261024	06-10-50,5	6,35	9/32-40 UNS	10,0	85,5	71,2	34,4	24,0	8,5	40,5	45,0	0,333
99261025	06-10-130	6,35	9/32-40 UNS	10,0	85,5	71,2	34,4	24,0	8,5	120,0	45,0	0,458
99261323	06-12,5-53	8,0	9/32-40 UNS	12,5	85,5	71,2	34,4	24,0	8,5	40,5	45,0	0,379
99261324	06-12,5-132,5	8,0	9/32-40 UNS	12,5	85,5	71,2	34,4	24,0	8,5	120,0	45,0	0,504